

TT-2 TRASH DUMP TRAILER

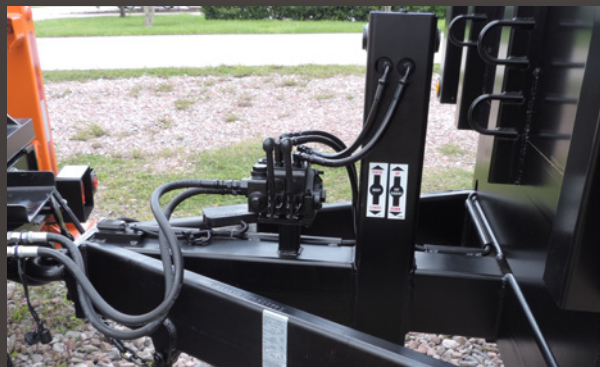

HANDBUILT HEAVY DUTY

The TT-2 is our flagship trailer. It's our industry-leading body, on top of a frame that's handbuilt for maximum durability. A high-capacity jack-stand and rectangular tubing make this the toughest trailer around.

Here Are a Few More Benefits:

- 🔧 **Tackle the Tough Jobs**
Hoist is capable of dumping 4 times the legal payload
- 🔧 **Built for Strength**
High-capacity jack stand for disconnecting the loaded trailer
- 🔧 **Customized to Your Needs**
Available with a single or tandem axle, and in a standard or Harbox® body



American born. American made.
Efficient, dependable one-man operations for secure solid waste removal. Revolutionizing grapple trucks since 1957 and home to the original, industry-defining Lightning Loader®.

WE BUILD LEGENDS®.

SYSTEM DESCRIPTION

- Tongue-mounted manual jack stand built to support a disconnected, fully loaded trailer
- Control Valve for Hoist Operation
- Quick couplers for lights and brakes
- 23 Ton Hoist
- Designed for use with a Petersen RL-3 Lightning Loader® grapple truck

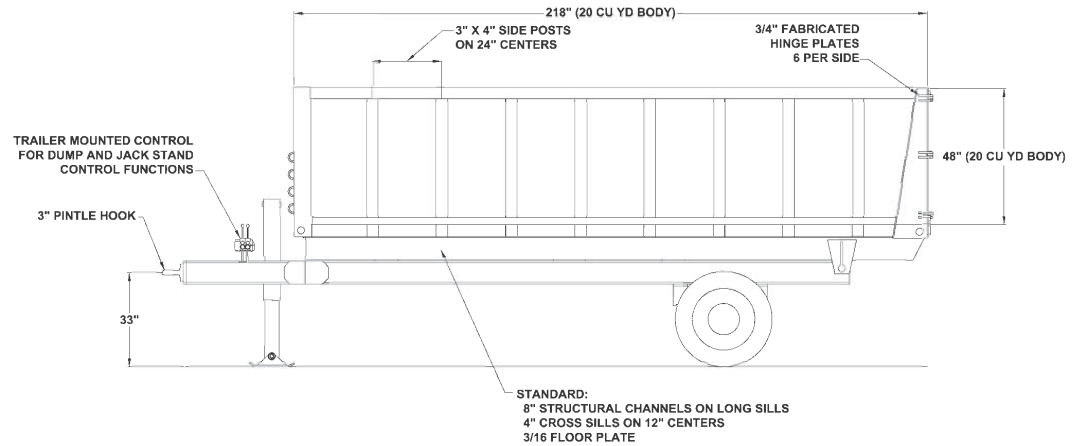

STANDARD FEATURES

Body Floor	3/16" single sheet steel plate	Frame	2" x 8" x 1/4" steel tubing with 6 cross members.	Paint	High grade primer and enamel finish.
Cross Sills	4" structural channel on 12" centers	Barn Doors	Positive locking mechanism on top and bottom, 3 hinges per door with two 5/8" thick straps	Draw Bar	Vertical load capacity of 15,000 lbs. and 3" pintle eye.
Body Sides	10 gauge steel continuously welded to floor	Body Hoist	23 ton dual hydraulic cylinder hoist	Headboard	10 gauge steel continuously welded to the floor, Top rail is 3" x 4" formed channel.
Axles	15,000 lb. capacity with dual wheels and tires. Electric brakes are standard. (Also available with tandem axle - see options below)			Side Posts	3" x 4" x 10 gauge formed channels on 24" centers, 1/4" steel plate formed rear corner posts
Body Lights	Meets federal lighting standards, includes elevated brake lights and LED body lights for increased visibility. Mud flaps installed behind rear wheels.				

POPULAR OPTIONS

- 24 or 27 cubic yard body
- Hydraulic jack stand, with additional control valve
- Manual or electric load covering device
- Twin 10,000 lb. axles
- Air brakes
- Power pack for self-dumping
- 3/16" reinforcement plates between floor and sides
- Continuous welds for side posts
- Heavy Duty or Hardox® Body

CONTACT PETERSEN INDUSTRIES FOR COMPLETE SPECIFICATIONS.

SCAN TO LEARN MORE



4000 SR 60 West
Lake Wales, FL 33859

1.800.930.LOAD (5623)



PETERSENIND.COM
Contact Us Today To Learn More