

ROUTE ASSISTANT®



JACK-OF-ALL-TRADES

The Route Assistant® is an option for the TL-3 Lightning Loader® unit. It incorporates a side-loading trough to the front of the dump body and can be a full-trough system or half-trough and cart tipper. The Route Assistant® option truly makes the TL-3 the Jack-of-all-trades loader. The trough can be used to quickly pick up piles of sticks, leaves, or small items by hand and the tipper can be used for missed carts on the route. It is available on a standard or stand-up-right-hand-drive chassis.

- Use the Loader for the Heavy Stuff
- Use the Route Assistant® for the Light Stuff
- Get it All With One truck



American born. American made.
Efficient, dependable one-man operations for secure solid waste removal. Revolutionizing grapple trucks since 1957 and home to the original, industry-defining Lightning Loader®.

WE BUILD LEGENDS®.

PETERSENIND.COM | 800.930.LOAD (5623)

GENERAL SPECIFICATIONS

Reach (20 ft. 7 inches)
 Main Boom & Tip Boom (16 ft. 7 inches)
 Tip Extension (4 ft.)

Tare Weight (empty) 27,000 est.

Outrigger Span (11 ft. 8 in.)

Dump Body Hoist Capacity (23 tons)

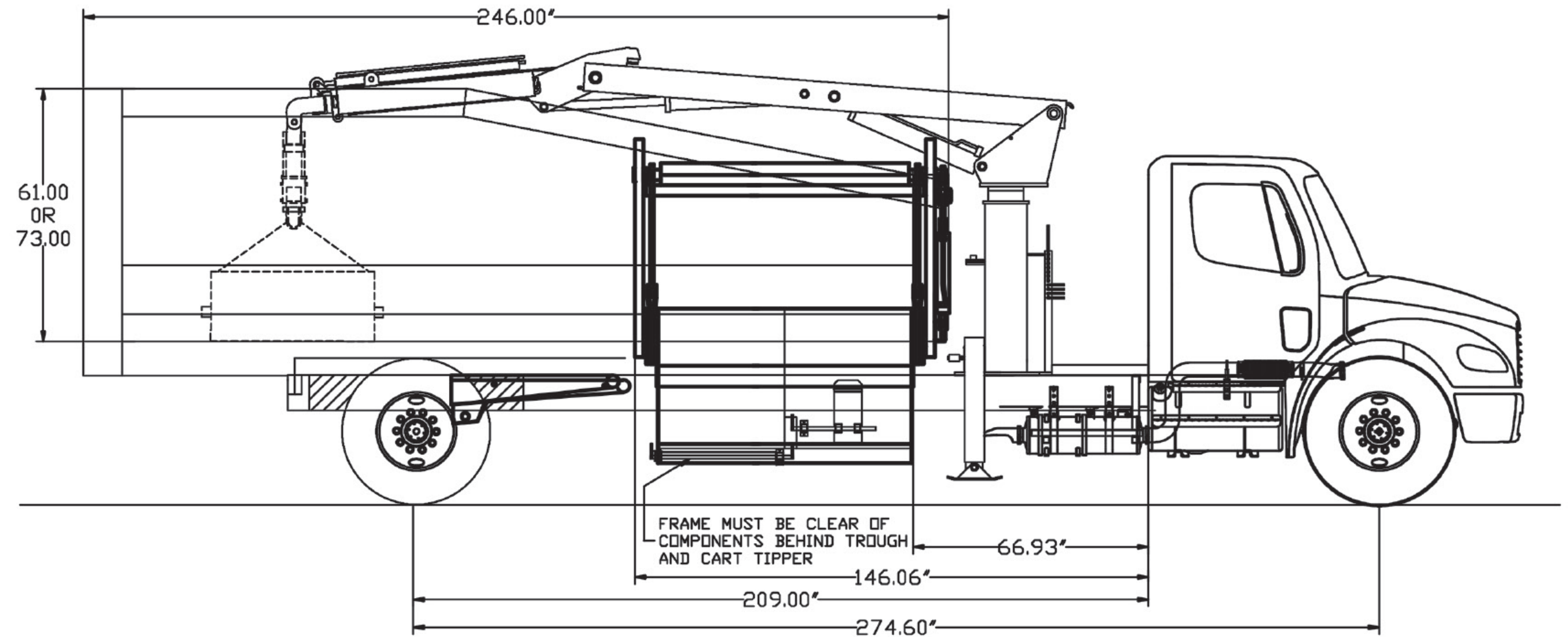

Tandem Axle is Also Acceptable

FEATURES

- Easy to operate controls
- User-friendly side loading
- Low maintenance - single cylinder loading operation (patented)
- Manual and semi-automatic cart loading
- No chassis drop frame requirement

RECOMMENDED CHASSIS (MINIMUM)

Body Style	Conventional Cab	GVW Rating	39,000 lbs. Minimum
Cab-to-Axle Dimension	209 in.	Frame	1,500,000 RBM
Front Axle Rating	14,000 lbs	Engine	240 HP Diesel
Rear Axle Rating	25,000 lbs	Transmission	Automatic

*Contact Petersen Industries for Tandem axle chassis specifications

LIFT CAPACITY

Radius	Lift Capacity
10 ft. radius	7,100 lbs.
16 ft. radius	4,400 lbs.
20 ft. radius	3,200 lbs.

CONTACT PETERSEN INDUSTRIES FOR COMPLETE SPECIFICATIONS.

SCAN TO LEARN MORE



4000 SR 60 West
 Lake Wales, FL 33859

1.800.930.LOAD (5623)



PETERSENIND.COM
 Contact Us Today To Learn More